

STAGE BRACES & WEIGHTS

STAGE & WALL BRACES

Stage Braces

Extendable braces like these are used to support lightweight scenery. They are secured to the flats with a screw eye which locates with the hooks on the brace. The foot is designed to marry with our stage weight but it is also drilled for use with either Stage Screws or Stage Bolts into Boss Plates [page 170]. Made from tulipwood with bright zinc-plated fittings. We also include a small brace, useful for ground rows. Special sizes can be made to order. Fixings needed: 55 mm screw eyes [see below].

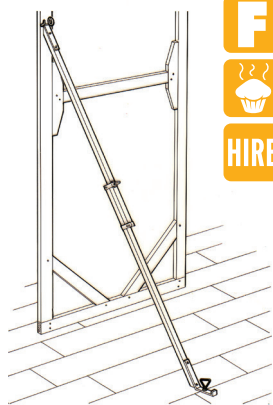

code	description	closed length	open length	price	10+
FHS018GRK		760mm	1mm	£37.38	£33.64
FHS018K		1.2m	2mm	£43.73	£39.36
FHS019K		1.7m	3mm	£49.78	£44.80
FHS020K		2.2m	4mm	£52.03	£46.83
FHS702	Spare Cowhorns			£6.60	

Steel Scenery Braces

A range of fixed and extendable steel stage braces. Crackle black finish with bright zinc-plated inner section.

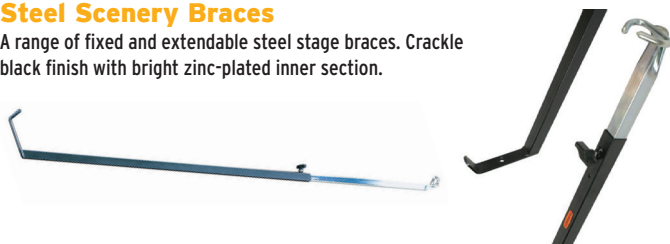

code	length	price	10+
DOUT60600	2m	£45.25	£40.73

code	closed length	open length	price	10+
DOUT60000	1m	2m	£74.60	£66.82
DOUT60100	1.5m	3m	£85.30	£76.40
DOUT60200	2m	4m	£95.97	£85.95

Wall Braces

Similar to a Stage Brace but with an end fitting which will locate with a drilled angle iron mounted on studio walls. This enables the studio floor space to be kept clear whilst holding the flats solidly in place.

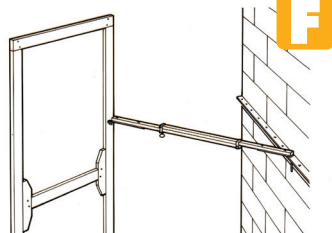

code	closed length	open length	price
FHS021K	1.2m	2m	£38.81
FHS022K	1.7m	3m	£44.14

BRACE ACCESSORIES

Stage Screws and Stage Bolts

The Stage Screw will drive easily into timber floors to secure stage braces in place without the need for weights. The Stage Bolt serves the same purpose but is used in conjunction with a Boss Plate [see page 170].

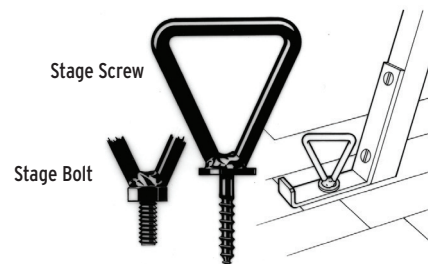

code	description	price	20+
FHS024	Stage Screw	£4.35	£3.90
FHS025	Stage Bolt	£2.85	£2.55

Screw Eye

The most popular way of attaching stage braces to flats. The 55 mm x 12 g size is the best size for this purpose. A full range of screw eyes are available [page 280].

NB: Brace Eyes are no longer made.



code	description	size	size	price	100+
FIX3161	Screw Eye	55mm	55mm	£0.29	£0.26

STAGE WEIGHTS

Stage Weights

Flints famous 12.5 kg* Stage Weights are made of cast iron with a malleable iron carrying handle. Why 12.5kg? Many years ago stage weights were typically 15 kg, but modern manual handling practice is to limit loads to 25 kg, hence a 12.5 kg stage weight in each hand. They stack easily on their location lugs and have slots which let them sit safely on Stage Braces and French Braces.

The central area is hollowed right through so they cannot be used as ashtrays [nostalgia] or nail stores! The top edge has deliberately not been rounded over so it remains useful for cutting sash or wire with a hammer. Flints holds massive stocks of Stage Weights both for hire and sale. We can customise Stage Weights with your logo for orders of fifty plus. *Weights can vary plus or minus 5%. Design right applies. Standard weights are supplied painted black but custom weights are self-colour. Size: 211 x 211 x 60 mm. The big question is "Where do they all end up?"

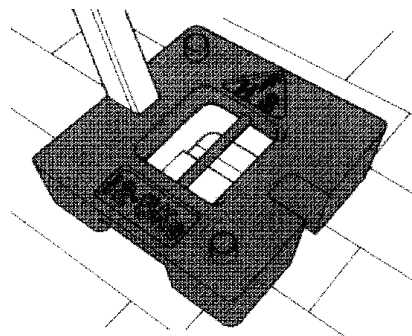

code	description	weight	price	10+	76+
FHS023	Stage Weight	12.5kg [+/-5%]	£38.50	£36.50	£34.50
FHS023L	Custom Logo Weight		P.O.A. [50+ minimum order only]		

TV Pattern Weights

Similar to our standard Stage Weight but with the addition of a 29 mm receiver with locking-off wing bolt. Supplied painted black. *Weights can vary plus or minus 5%. Stage weights do not qualify for free delivery.



code	weight	price	10+	80+
FHS023TV	12.5kg [+/-5%]	£57.35	£51.62	£48.75

Counterweights

Our 10kg* Counterweight has two large holes with rounded entries to allow ropes or karabiners to pass through for hauling to the fly floor. Supplied self-colour. Delivery charged at cost. *Weights can vary plus or minus 5%. Prices are for each weight. Size: 325 x 153 x 42 mm [Lug width: 60 mm].



code	weight	price	10+	50+
FHS109	10kg [+/-5%]	£39.90	£33.55	£31.50

WEIGHT SKATE

Weight Skate XL

Flints is synonymous with Stage Weights but we haven't ever stocked anything to help you move them around... but now we have the Weight Skate; designed to carry up to 24 stage weights with a welded steel frame that weights neatly stack into. Think of this like a very fancy and much safer dolly. The frame extends on two sides for you to have a two handed grip whilst manoeuvring. Great for moving weights around but also a compact weight storage frame with heavy duty braking castors and a black finish, so can be discretely stowed away backstage. The Weight Skate can also be customised with your own logo if you wish, please get in touch with us for a quote!

Specification: Dimensions: 53cm (W) x 52cm (H) x 54cm (D)



code	description	width	height	depth	price
FHS023WSXL	Weight Skate XL	53cm	52cm	54cm	£400.00
FHS023WSXLK	Weight Skate XL + 20 Stage Weights	53cm	52cm	54cm	£995.00

SANDBAGS

Sandbags

Made from heavy canvas with strong webbing which secures the 70 mm diameter galvanised ring. They are sold empty or filled and are fitted with a heavy-duty zip and velcroed webbing to save having to sew them up after filling. We also have a black version. Sandbags are the preferred weight for the retrieval of otherwise unloaded hemp lines from the grid but obviously they have many other uses.

SPECIFICATION: Size: 300 x 200 x 70 mm [thickness when filled]. Approximate weight when filled: 3.5 kg [+/-5%]. See also Hessian Sandbags for filling on page 108.



code	description	price	10+
FHS026	Unfilled plains canvas	£9.19	£7.88
FHS026B	Unfilled black canvas	£9.66	£8.40
FHS026FK	Filled plain canvas	£10.90	£9.80
FHS026BFK	Filled black canvas	£10.90	£9.80

Heavy Black Water Resistant Weight Bag

These black bags have a watertight screw top 3.5 L container inside them and a drawstring top. They can be filled with water, sand [or marble dust], steel shot or lead shot giving a variety of weights up to a maximum of 25 kg. When used with water they can be toured empty and filled at each venue with a measured amount of water to give your desired weight. The Weight Bag is supplied unfilled. For Marble Dust, steel shot, and lead shot see alongside. This new version of the Weight Bag includes an outer sleeve which protects the straps from wear and is fully rated to the working load limit of 25 kg with the certificate of conformity included.



code	capacity	price
FHSHWB	25kg	£96.66

Pipe Sling Weight Bag

These sand bags are manufactured from heavy duty water repellent black Cordura. They are double seamed with zipped openings for easy filling. Supplied empty.



code	capacity	price
DOUG3301	16kg	£53.67

Small Tubular Weight Bag

These neat small steel shot bags have a variety of uses and are often preferable to using solid sash weights which can be noisy or cause injury. Fitted with a 25 mm diameter ring at the top. Weights can vary plus or minus 5%. Size: 150 x 50 mm [when flat].



code	weight	price
FHS026T	500g [+/-5%]	£12.95

STAGE BRACES & WEIGHTS / CLEATS

Sausage Weight Bags

Can be used to weigh down the base of cloths and prevent light leaks. The bags with delta rings can be used to help ropes fly-in or for quiet sash window counterweights. We now fill these bags with steel shot to avoid unnecessary handling of lead by our staff. They are slightly lighter than the old ones but still really heavy!



code	description	Colour	weight	length	price
FHSROH5	Plain	White	3kg	500mm	£27.70
FHSSWB5	Delta rings each end	Black	3kg	500mm	£32.58
FHSSWB1	Delta rings each end	Black	6kg	1m	£53.70

CLEATS

Cleats should be fitted at a slight angle to the direction of the pull of the rope. The rope should make one full turn around the main body of the cleat before crossing over the arms three or four times. The final locking hitch should only be done when there is no load on the rope or it will become jammed.

Flyrail Cleats [Cast Iron and Alloy]

Specialist fittings intended for tying-off manila and polyester ropes. These fittings should be securely bolted to a fly rail or wall and are intended to take the heavy loads associated with hand-hauled flying. To keep the fly floor clear of lines try to choose the largest cleat possible so the excess line can be neatly stored on the cleat. Fixings: M10 bolts or coach screws.



code	Material	length	price
WIR454	Cast Iron	225mm	£17.33
WIR455	Cast Iron	300mm	£17.75
WIR455A	Aluminium	285mm	£25.09
WIR456A	Aluminium	375mm	£33.47
WIR456	Cast Iron	375mm	£21.75
WIR457	Cast Iron	450mm	£29.00
WIR457A	Aluminium	450mm	£58.57

WEIGHT FILLING OPTIONS

Lead

We are keen to avoid our staff being exposed to lead so we now use steel shot whenever possible. The steel shot we supply is of excellent quality and is only a little lighter than the lead shot. We still sell lead shot but only in sealed units.

Lead Shot

For filling very heavyweight bags. The density of solid lead is 11,340 kg/m³. A one litre paint kettle filled with lead shot would weigh 7.95 kg.



code	weight	price
FHS026LS	5kg	£35.00

Steel Shot

For filling heavyweight bags. The density of solid steel is 7,850 kg/m³. A one litre paint kettle filled with steel shot would weigh 5.6 kg.



code	weight	price
FHS026SS	5kg	£28.56

Marble Dust

We use Marble Dust to fill our sand bags as it is clean and supplied very dry. The density of solid marble is 2,563 kg/m³. A one litre paint kettle filled with marble dust would weigh 1.92 kg. We no longer sell Marble Dust by the kilo and instead get them pre bagged into handy 4 kg bags. We took this decision to minimise airborne dust in the warehouse which is not only a health hazard but also means we have to tickle everything with a feather duster before we send it out! Grain size: 300 - 710 micron.



code	weight	price
PAT8674 NEW	4kg	£4.50
PAT867B	25kg	£22.62

Tying ropes to cleats



If the cleats are very large it may be possible to just hook any excess rope over the cleat. Normally this is not possible and another method is needed. Coil up the excess rope working away from the cleat but leave about 1 m slack between the cleat and the start of your coil. Working outwards towards the loose end allows any twist to escape. Finally, pass your hand through the coil, grab the slack length, wrap it around the coil and hook it up.

For the demo video visit our YouTube channel www.youtube.com/flintstheatre.

There may be times when a Rope Clutch or Rope Lock [page 240] or the lovely Tibloc Ascender [page 359] might be more appropriate for your job.